

FSB Aircraft Maintenance DE.145.0018	<h1>A/C-Weighting Report</h1>		Page: 1 von 1
	AQUILA AT01 / AT01-100		

Type:	AT01	Serial-No.:	AT01-146	Registration:	F-GZPL
Equipment-List Reference:			11.10.2021	Reason for weighing:	Repair

Weighing configuration according to flight manual:

Reference Datum:	Leading edge of wing root rib
Horizontal reference line:	Wedge of 5,5° on fuselage tube aligned with spirit level acc. to sketch be
Weighing condition, Remarks:	incl. Brake fluid, engine oil, coolant and unusable fuel (10.4 liters)

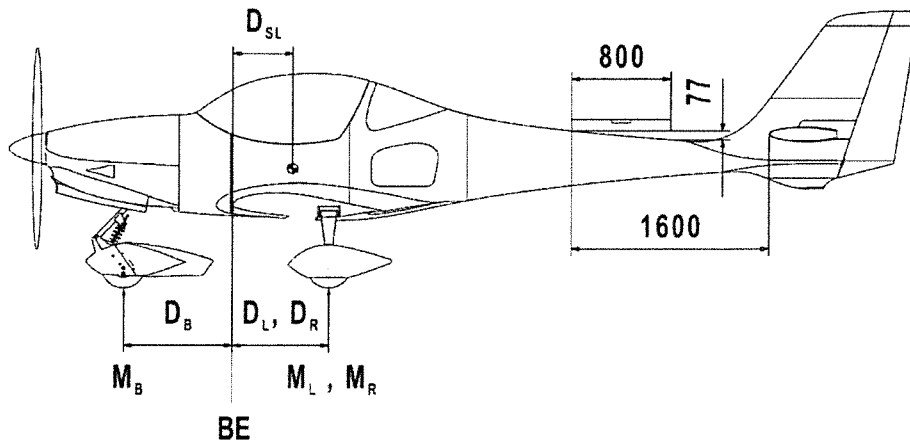

Position	Brutto (Kg)	Tare (Kg)	Net weight (Kg)	Lever arm (m)
Nose wheel			$m_B = 107,0$	$D_B = -0,840$
Left main wheel			$m_L = 199$	$D_L = +0,770$
Right main wheel			$m_R = 200$	$D_R = +0,780$
Instruments			$m_i = 0$	$D_i = +0,000$
Empty weight $m_{empty} = m_B + m_L + m_R + m_i =$				506,0 (Kg)
Empty weight moment $MO_{empty} = m_B * D_B + m_L * D_L + m_R * D_R + m_i * D_i =$				219,35 (Kgm)
Empty weight C.G. $D_{C.G.} = MO_{empty} / m_{empty} =$				0,433 (m)
Max. useful load = $MTOW - m_{Leer} =$		750	-	506
Max. load in the seats 2 x 110 kg				

The aircraft empty CG stays within the approved range (between 0,427 and 0,523 m).

All determined aircraft weight data are transferred to AFM chapt. 6.3.

Trim weight installed? Yes

Total weight of the trim weight: 1,9 Kg

Schönhagen, 11.10.2021
Plate / Date



Zahradnik
Signature CS